

N220 X18.3684 Y39.8801 Z-16.873 A3
N230 X18.4538 Y39.9275 Z-16.7356 A
N240 X18.5386 Y39.9932 Z-16.5432 A
N250 X18.6194 Y40.0521 Z-16.3565 A
N260 X18.7042 Y40.119 Z-16.0706 A
N270 X18.789 Y40.1859 Z-15.7297 A
N280 X18.8635 Y40.2577 Z-15.33 A32
N290 X18.9471 Y40.553 Z-14.7657 A3
N300 X19.0216 Y40.849 Z-14.238 A3
N310 X19.096 Y41.1442 Z-13.7823 A
N320 X19.1706 Y41.4394 Z-12.9925 A
N330 X19.2451 Y41.7356 Z-12.4307 A
N340 X19.3097 Y41.3899 Z-11.4808 A
N350 X19.3754 Y41.5659 Z-10.6264 A
N360 X19.436 Y41.6913 Z-9.9075 A33
N370 X19.496 Y41.8598 Z-9.2106 A33
N380 X19.556 Y42.0283 Z-8.5415 A3

Mastercam

SHAPING THE FUTURE
OF MANUFACTURING™

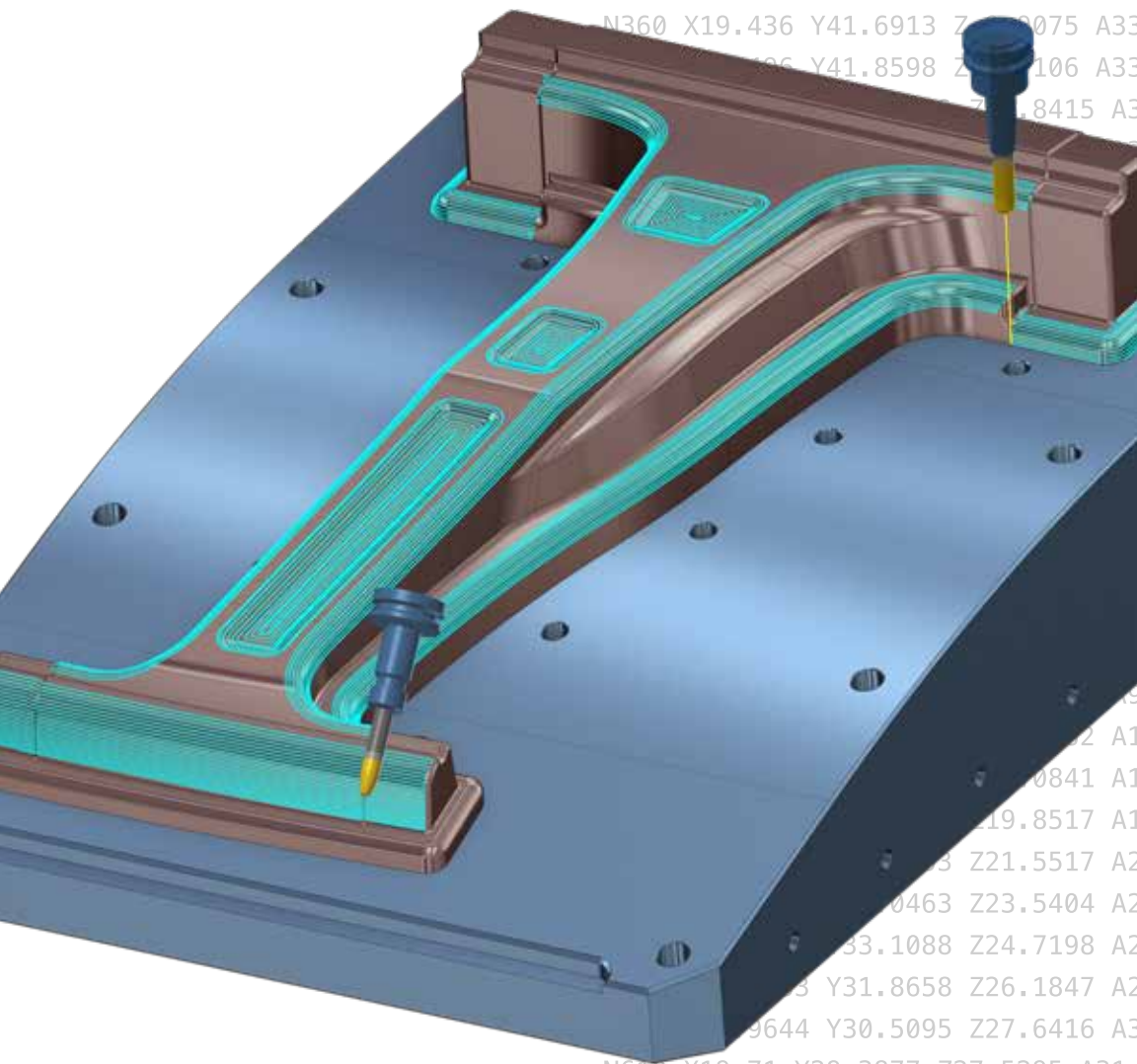

N390 X19.6208 Y42.1056 Z-7.8415 A3
N400 X19.6808 Y42.2741 Z-7.192 A3
N410 X19.7408 Y42.4426 Z-6.5425 A3
N420 X19.8008 Y42.6111 Z-5.893 A3
N430 X19.8608 Y42.7796 Z-5.2435 A3
N440 X19.9208 Y42.9481 Z-4.594 A3
N450 X19.9808 Y43.1166 Z-3.9445 A3
N460 X20.0408 Y43.2851 Z-3.295 A3
N470 X20.1008 Y43.4536 Z-2.6455 A3
N480 X20.1608 Y43.6221 Z-1.996 A3
N490 X20.2208 Y43.7906 Z-1.3465 A3
N500 X20.2808 Y43.9591 Z-0.697 A3
N510 X20.3408 Y44.1276 Z-0.0475 A3
N520 X20.4008 Y44.2961 Z-0.602 A3
N530 X20.4608 Y44.4646 Z-1.2525 A3
N540 X20.5208 Y44.6331 Z-1.903 A3
N550 X20.5808 Y44.8016 Z-2.5535 A3
N560 X20.6408 Y44.9701 Z-3.204 A3
N570 X20.7008 Y45.1386 Z-3.8545 A3
N580 X20.7608 Y45.3071 Z-4.505 A3
N590 X20.8208 Y45.4756 Z-5.1555 A3
N600 X20.8808 Y45.6441 Z-5.806 A3
N610 X19.71 Y29.3877 Z27.5295 A31.
N620 X19.5836 Y28.6813 Z27.6213 A3
N630 X19.5544 Y28.3717 Z27.8717 A3
N640 X19.5252 Y28.0621 Z28.1221 A3
N650 X19.3013 Y27.6442 Z27.3554 A3
N660 X19.2721 Y27.3346 Z27.6058 A3
N670 X19.2429 Y27.025 Z27.8562 A3
N680 X18.8943 Y26.2535 Z26.917 A-3
N690 X18.7554 Y25.7716 Z26.794 A31
N700 X18.6089 Y25.3174 Z26.6228 A-
N710 X18.465 Y24.8384 Z26.4952 A31

WHAT'S NEW IN
Mastercam 2019

WHAT'S NEW



Mastercam 2019 helps streamline your entire process, from job setup to job completion.



Preparation/ Setup

Improve efficiency and job setup time with enhanced CAD model import support, improved part preparation, fixture setup, and expanded support for model-based definition (MBD).

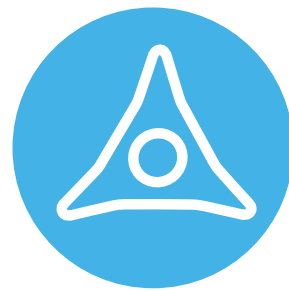

Tool Support

Expanded digital tool libraries deliver accurate tool assembly models and access to the latest cutting tool technology, with added support for Accelerated Finishing™ and Sandvik Coromant PrimeTurning™ tools.

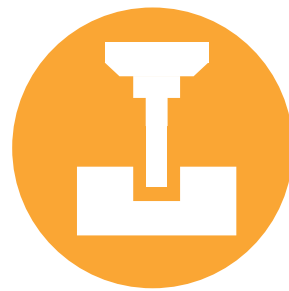

CNC Programming

Increase productivity and programming efficiency with new 2D through 5-axis toolpath improvements, new Lathe and Mill-Turn machining support, and new Swiss machine functionality.



Validation

Improved toolpath and machine simulation, toolpath graphics, and other verification and analysis tools provide greater programming assurance for confident, informed decisions before the job is run.



Job Management & Documentation

An array of system-level enhancements improves job documentation and management — addressing quality and certification initiatives with new visualization and section view tools, improvements to view and setup sheets, and much more.

For more details, visit whatsnew.mastercam.com.

Dynamic Motion™ technology continues to innovate.

Dynamic Motion toolpaths maximize material removal rate and can reduce cycle times by 25 to 75%. Dynamic Motion uses a proprietary set of rules to continually adjust toolpath motion to maintain a constant chip thickness everywhere on the part. This results in consistent machining performance, shorter cycle times, and longer tool life.



Accelerated Finishing™ technology gives you new ways to work faster.

Mastercam's Accelerated Finishing technology, simply called Finish, is the next leap forward in addressing today's innovative profile tools and processes aimed at greater efficiency and higher machining productivity. Collaborating with the industry's smartest tool manufacturers, our software takes full advantage of these new tool designs to dramatically reduce finishing cycle times while improving surface finish.



Some of the new features available in Mastercam 2019 include:

- Automate solid chamfering
- New Equal Scallop provides superior surface finish
- Automate with 3- and 5-axis deburr/edge break
- Boundary smoothing improves surface quality
- Power Surface provides high-end construction and surface editing
- New Solid Hole plus hole axis automates holmaking
- 3D turning tool support
- New 3D Lathe Tool Designer
- Expanded surface machining support for lens and taper profile tools
- Expanded CoroPlus® ToolLibrary and MachiningCloud support
- Sandvik Coromant PrimeTurning™ ID tool support
- New Face Groove strategies improve machining efficiency
- Simplified Mill-Turn tool loading
- New automation for single-turret lathes
- New Mastercam Lathe for Swiss
- Toolpath display and visual enhancements
- New Solids Manager organization tools
- New section views improve visualization and documentation needs
- Toolpath verification and simulation enhancements

These are just a few of the powerful new tools in Mastercam 2019. To see them in action or for more details, visit [whatsnew.mastercam.com](https://www.whatsnew.mastercam.com).

Mastercam®

CNC Software, Inc.
671 Old Post Road
Tolland, CT 06084

CIMQUEST

3434 RT 22 West, Suite 130 • Branchburg, NJ 08876
• Phone: 866-277-8778 • Fax: 732-699-0404 •
www.cimquest-inc.com